

SPECIFICATIONS SCHEDA TECNICA

HLRM 45-5S

OVERALL DIMENSIONS DIMENSIONI DI INGOMBRO

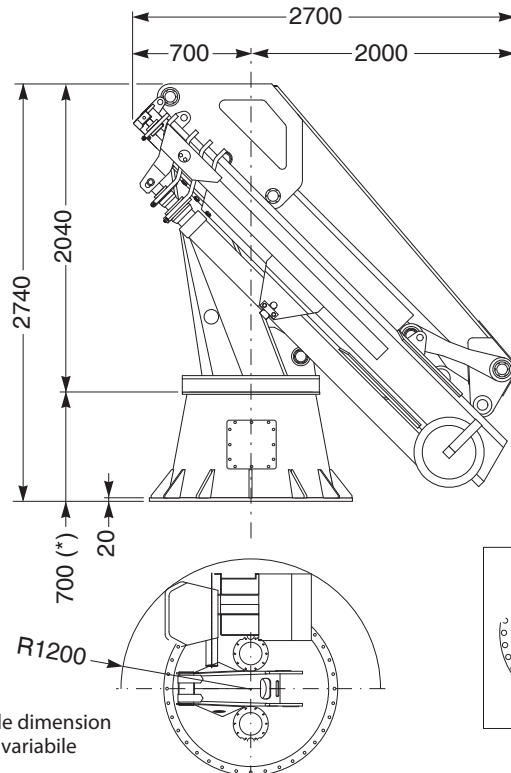

1" (inch) = 25,40 mm

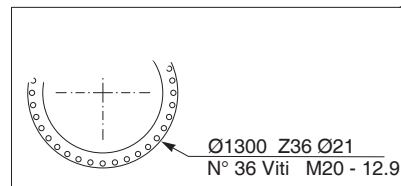
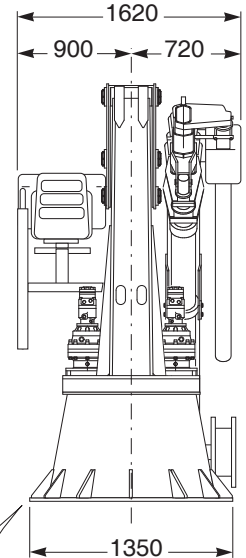

(*) Variable dimension
Quota variabile

TECHNICAL DATA DATI TECNICI

<i>Hydraulic extensions</i>	Sfili idraulici	N°	5
<i>Max torque</i>	Momento massimo	t·m	45
<i>Slewing torque</i>	Coppia di rotazione	kg·m	8000
<i>Slewing angle (continuous)</i>	Angolo di rotazione (continuo)	°	360
<i>Pump capacity</i>	Portata della pompa	lt/min	60
<i>Max working pressure</i>	Pressione massima di esercizio	bar	285
<i>Crane weight 'empty'</i>	Peso gru a vuoto	kg	4900
<i>Quantity of oil recommended</i>	Quantità di olio consigliata	lt	250
<i>Slewing speed</i>	Velocità di rotazione	rpm	0,8
<i>Main boom lifftin time</i>	Tempo di sollevamento 1° braccio	sec	50
<i>Secondary boom articulation time</i>	Tempo di articolazione 2° braccio	sec	50
<i>Boom element extension time</i>	Tempo di estensione sfili braccio	sec	80

OPTIONALS A RICHIESTA

<i>1500 kg direct pull winch rope Ø10</i>	Argano da 1500 kg in tiro diretto fune Ø10
<i>Winch limit switch</i>	Finecorsa argano
<i>Slewing limit switch (400°)</i>	Finecorsa rotazione (400°)
<i>Cab with windows and wipers</i>	Cabina con vetri e tergicristalli
<i>Size 6 electrohydraulic power pack (HP 41)</i>	Taglia 6 centralina elettroidraulica (HP 41)
<i>Control panel out of the crane</i>	Comandi distributore fuori macchina
<i>1st manual extension 1000 kg @ 16,72 m</i>	1° prolunga meccanica 1000 kg @ 16,72 m



Truck Loaders & Marine Cranes



WORKING DIAGRAM DIAGRAMMA DI LAVORO

HLRM 45-5S

(ONLY FOR USE WITH HOOK - SEA STATE - 0 - OR HARBOUR CONDITION)

I dati contenuti in questa scheda sono puramente indicativi. • The technical data contained in this card are only indicative.

